

BExCBG05-05 Dual Xenon Beacon

The flameproof BExCBG05-05 dual xenon beacons are suitable for Zone 1, 2, 21 & 22 applications.

The BExCBG05-05D dual 5 Joule beacons are ideal for general signalling duties whilst their robust construction makes installation in the harshest of environments possible. The beacons may be connected from a single supply for simultaneous operation or from separate supplies for independent operation. Additional features include automatic synchronisation on multi-beacon systems and stainless steel guard and mounting bracket as standard.

The BEx range features enclosures manufactured from corrosion proof, marine grade copper free LM6 aluminium which is phosphated and powder coated. All models have two M20 cable entries, large termination areas and an ingress protection of IP67.

Features:

- Automatic synchronisation on multi-beacon system.
- Beacons can be set to 'flip-flop' alternating mode with other units on multi-beacon systems.
- Xenon tubes mechanically secured against shock & vibration
- Glass lens & Stainless Steel guard
- Very large termination area.
- Ratchet adjustable stainless steel 'U' bracket.

Approvals:

- ATEX certificate: KEMA 01ATEX2222X, EN 60079-0 : 2006, EN 60079-1 : 2007, EN 61241-0 : 2006, EN 61241-1 : 2004
- IECEx certificate: IECEx KEM 10.0024, IEC 60079-0 : 2004 (Ed4), IEC 60079-1 : 2007 (Ed6), IEC 61241-0 : 2004 (Ed1), IEC 61241-1 : 2004 (Ed1)
- GOST-R certificate: POCC GB.JB05.B02205
- Inmetro certificate: 10-IEEx-0010

Part codes:

Part Code:

BExCBG0505D**

Classification:

ATEX/IECEX:
 II 2G Ex d IIB T4 Ta. -50°C to +70°C
 II 2G Ex d IIB T5 Ta. -50°C to +55°C
 II 2D Ex tD A21 IP67 T115°C
 based on max. Ta. of +70°C
 GOST-R:
 1ExdIICT4 Ta. -50° to +55°C
 DIP A21 TA T4

** = Voltage & lens colour reference:

Voltage options: 12DC, 24DC, 48DC, 115AC, 230AC

Lens colour options: -A (Amber)

[specify two] -B (Blue)
 -C (Clear)
 -G (Green)
 -R (Red)
 -Y (Yellow)

e.g. BExCBG0505D115AC-A/R



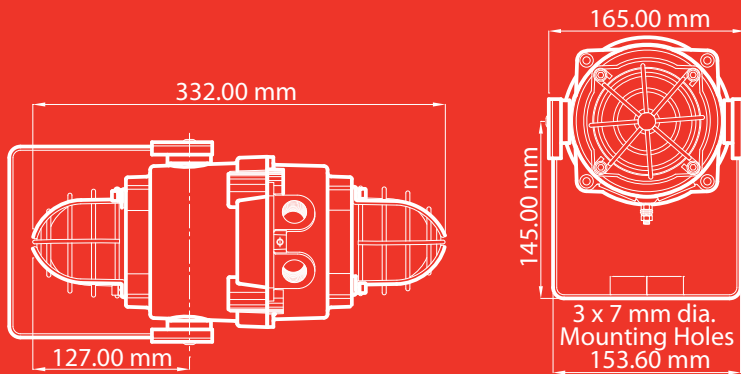

Specification:

Energy:	5 Joules x 2 (5Ws)
Flash rate:	1Hz (60 fpm)
Peak Candela:	34,812 cd x 2
Effective Intensity cd:	105 cd* x 2
Lens colours:	Amber, Blue, Clear, Green, Red & Yellow
Voltages DC:	12vdc; 24vdc; 48vdc
Voltages AC:	115vac; 230vac
Ingress protection:	IP66/67
Housing material:	Marine grade copper free LM6 Aluminium
Housing finish:	Phosphated & powder coated finish - anti-corrosion.
Colour:	RAL3000 Red (others available on request)
Cable entries:	Dual M20 ISO (one stopping plug included)
Terminals:	0.5 to 4.0mm ² cables.
Line monitoring :	Min. 500 Ohm 2w, or 3k3 Ohm 0.5w res. or diode (dc versions).
Tube life :	Emissions are reduced to 70% after 8 million flashes
Weight :	DC: 4.00kg AC: 4.35kg

Current consumption: [per Xenon Beacon]

Version:	Voltage range:	Current:
12V dc	10-14V dc	750mA
24V dc	20-28V dc	300mA
48V dc	42-54V dc	180mA
115V ac	50Hz/60Hz +/-10%	140mA
230V ac	50Hz/60Hz +/-10%	55mA

Effective Candela lens colour factor:

Amber	Blue	Clear	Green	Red	Yellow
0.51	0.12	1.00	0.49	0.15	0.86

* All candela data is representative of performance with clear lens at optimum voltage.

Assemblies:

The products from the BEx range are available as multiple unit assemblies with and without junction boxes. See the BExP data sheet for further info.

