

# MCA112-L1 Alarm Sounder & L.E.D. Beacon

The MCA112-L1 combines a high output, 119dB(A) alarm sounder with a multi-function L.E.D. beacon. With a robust, fire retardant, IP66 & IP67 housing, the MCA112-L1 is particularly suitable for harsh environments with high ambient noise levels. The sounder & beacon can be operated individually or simultaneously.

## Features:

- Automatic synchronisation on multi-sounder system.
- Continuously rated.
- Large termination area.
- Stainless steel fixings.
- Ratchet adjustable stainless steel 'U' bracket for 360° positioning.
- Duplicate cable terminations. (in & out for daisy-chain installations).
- Tropicalisation available on request.
- Available with custom tone configurations and frequencies.
- 'Programmable' version available:
  - 45 alarm tones
  - 4 remotely selectable stages
  - Any tone can be assigned to any stage
  - User configurable continuous frequency tone

## Approvals:

- UKOOA/PFEER compliant alarm tones.
- GOST-R approved. Cert: POCC GB-JB05-B02228

## Part codes:

Version:	Part code:
12V dc	MCA112L1DC12G-xx
24V dc	MCA112L1DC24G-xx
48V dc	MCA112L1DC48G-xx
24V ac	MCA112L1AC24G-xx
115V ac	MCA112L1AC115G-xx
230V ac	MCA112L1AC230G-xx
[xx] = L.E.D. / Lens colour: AM: Amber, BL: Blue, CL: Clear GN: Green, RD: Red, YW: Yellow	
Suffix part number with '-P' for programmable, 4 stage, 45 tone version.	



GOST-R

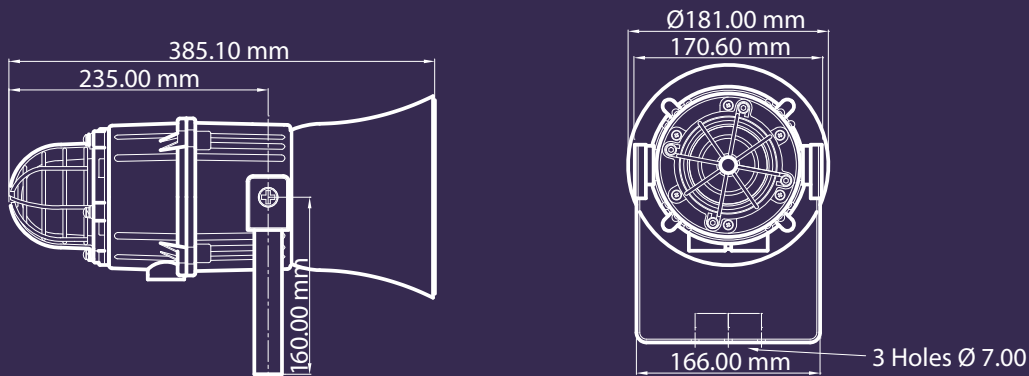

**Alarm sander:**

Version:	Voltage range:	Current mA:
24V dc	10-30V dc	200mA*
48V dc	35-60V dc	120mA*
24V ac	50/60Hz +/-10%	500mA
115V ac	50/60Hz +/-10%	100mA
230V ac	50/60Hz +/-10%	60mA

\* current at nominal voltage on Tone 2

**L.E.D.:**

Version:	Voltage range:	Current mA:
12V dc	10-50V dc	760mA
24V dc	10-50V dc	400mA
48V dc	10-50V dc	210mA
24V ac	50/60Hz +/-10%	380mA
115V ac	50/60Hz +/-10%	135mA
230V ac	50/60Hz +/-10%	65mA

**Multi-function patterns:**

Mode:	Stage 1: [Selectable on board]	Stage 2: [Remotely selectable]	Stage 3: [Remotely selectable]
1	All L.E.D.'s on	Mode: 9	Mode: 6
2	Rotating: Slow1	Mode: 9	Mode: 1
3	Single Flash: 2Hz	Mode: 7	Mode: 1
4	Rotating: Fast 1	Mode: 3	Mode: 1
5	Rotating: Slow 2	Mode: 6	Mode: 1
6	Double Flash: 1Hz	Mode: 7	Mode: 1
7	Rotating: Fast 2	Mode: 8	Mode: 1
8	Double Flash: 2Hz	Mode: 9	Mode: 1
9	Alt. Side Flash: 2Hz	Mode: 7	Mode: 1

**Specification:**

Sounder:	
Maximum output:	119dB(A) @ 1 metre
Nominal output:	112dB(A) @ 1m +/- 3dB - Tone 2
No. of tones:	45 (UKOOA / PFEER compliant)
No. of stages:	3
Volume control:	Max. 112dB(A); Min. 100dB(A) - Tone 2
Effective range:	125m @ 1KHz
Voltages DC:	24V dc (10-30V dc); 48V dc (35-60V dc) [DC units can use 24V ac for single stage applications.]
Voltages AC:	24V ac; 115V ac; 230V ac
Stage switching:	Negative or positive Reverse polarity stage switching on DC units.

**L.E.D. Beacon:**

Light source:	Array of 32 high output L.E.D.s
Peak/Effective Candela:	11 cd*
Lens colours:	Amber, Blue, Clear (white L.E.D.s) Green, Red & Yellow
Voltages DC:	10-50V dc
Voltages AC:	24V ac; 115V ac; 230V ac

**General:**

Ingress protection:	IP66 & IP67 (Third party tested)
Housing material:	High impact UL94 V0 & 5VA FR ABS
Colour:	Grey (RAL7038)
Cable entries:	2 x M20 supplied with 1 blanking plug
Lens material:	Borosilicate glass dome with PC prismatic lens cover.
Guard:	Stainless Steel dome guard as standard
Terminals:	0.5 to 4.0mm <sup>2</sup> cables.
Operating temperature:	-25 to +55°C
Storage temperature:	-40 to +70°C
Relative humidity:	90% at 20°C.
Weight :	DC: 3.00kg AC:3.50kg

\*Candela measurements representative of performance with red lens at optimum voltage.

\*SPL data +/-3dB(A). Measured at optimum voltage.

**Tone table:**

Stage 1	Frequency Description	dB @ 1m	Stage 2	Stage 3
Tone 1	340 Hz Continuous	107dB(A) @ 1m	Tone 2	Tone 5
Tone 2	800/1000Hz @ 0.25 sec Alternating - BS5839 Alarm tone	112dB(A) @ 1m	Tone 17	Tone 5
Tone 3	500/1200Hz @ 0.3Hz 0.5 sec Slow Whoop - NEN 2575:2000	113dB(A) @ 1m	Tone 2	Tone 5
Tone 4	800/1000Hz @ 1Hz Sweeping	113dB(A) @ 1m	Tone 6	Tone 5
Tone 5	2400Hz Continuous	119dB(A) @ 1m	Tone 3	Tone 20
Tone 6	2400/2900Hz @ 7Hz Sweeping	116dB(A) @ 1m	Tone 7	Tone 5
Tone 7	2400/2900Hz @ 1Hz Sweeping	116dB(A) @ 1m	Tone 10	Tone 5
Tone 8	500/1200/500Hz @ 0.3Hz Sweeping	113dB(A) @ 1m	Tone 2	Tone 5
Tone 9	1200/500Hz @ 1Hz - DIN / PFEER P.T.A.P.	113dB(A) @ 1m	Tone 15	Tone 2
Tone 10	2400/2900Hz @ 2Hz Alternating	119dB(A) @ 1m	Tone 7	Tone 5
Tone 11	1000Hz @ 1Hz Intermittent	112dB(A) @ 1m	Tone 2	Tone 5
Tone 12	800/1000Hz @ 0.875Hz Alternating	112dB(A) @ 1m	Tone 4	Tone 5
Tone 13	2400Hz @ 1Hz Intermittent	119dB(A) @ 1m	Tone 15	Tone 5
Tone 14	800Hz 0.25sec on, 1 sec off Intermittent	113dB(A) @ 1m	Tone 4	Tone 5
Tone 15	800Hz Continuous	113dB(A) @ 1m	Tone 2	Tone 5
Tone 16	660Hz 150mS on, 150mS off Intermittent	109dB(A) @ 1m	Tone 18	Tone 5
Tone 17	544Hz (100mS)/440Hz (400mS) - AFNOR NF S 32-001	109dB(A) @ 1m	Tone 2	Tone 27
Tone 18	660Hz 1.8sec on, 1.8sec off Intermittent	109dB(A) @ 1m	Tone 2	Tone 5
Tone 19	1.4KHz-1.6KHz 1s, 1.6KHz-1.4KHz 0.5s - AFNOR NFC48-265	114dB(A) @ 1m	Tone 2	Tone 5
Tone 20	660Hz Continuous	109dB(A) @ 1m	Tone 2	Tone 5
Tone 21	554Hz/440Hz @ 1Hz Alternating	109dB(A) @ 1m	Tone 2	Tone 5
Tone 22	544Hz @ 0.875 sec. Intermittent	109dB(A) @ 1m	Tone 2	Tone 5
Tone 23	800Hz @ 2Hz Intermittent	113dB(A) @ 1m	Tone 6	Tone 5
Tone 24	800/1000Hz @ 50Hz Sweeping	112dB(A) @ 1m	Tone 29	Tone 5
Tone 25	2400/2900Hz @ 50Hz Sweeping	116dB(A) @ 1m	Tone 29	Tone 5
Tone 26	Bell	108dB(A) @ 1m	Tone 2	Tone 15
Tone 27	554Hz Continuous	109dB(A) @ 1m	Tone 26	Tone 5
Tone 28	440Hz Continuous	106dB(A) @ 1m	Tone 2	Tone 5
Tone 29	800/1000Hz @ 7Hz Sweeping	112dB(A) @ 1m	Tone 7	Tone 5
Tone 30	300Hz Continuous	107dB(A) @ 1m	Tone 2	Tone 5
Tone 31	660/1200Hz @ 1Hz Sweeping	112dB(A) @ 1m	Tone 26	Tone 5
Tone 32	Two tone chime.	108dB(A) @ 1m	Tone 26	Tone 15
Tone 33	745Hz @ 1Hz Intermittent	109dB(A) @ 1m	Tone 2	Tone 5
Tone 34	1000 & 2000Hz @ 0.5 sec Alternating - Singapore	109dB(A) @ 1m	Tone 38	Tone 45
Tone 35	420Hz @ 0.625 sec Australian Alert - AS2220	114dB(A) @ 1m	Tone 36	Tone 5
Tone 36	500-1200Hz 3.75sec /0.25sec. Australian Evac. - AS2220	108dB(A) @ 1m	Tone 35	Tone 5
Tone 37	1000Hz Continuous - PFEER Toxic Gas	113dB(A) @ 1m	Tone 9	Tone 45
Tone 38	2000Hz Continuous	112dB(A) @ 1m	Tone 34	Tone 45
Tone 39	800Hz 0.25sec on, 1 sec off Intermittent	116dB(A) @ 1m	Tone 23	Tone 17
Tone 40	544Hz (100mS)/440Hz (400mS) - AFNOR NF S 32-001	113dB(A) @ 1m	Tone 31	Tone 27
Tone 41	Motor Siren - slow rise to 1200 Hz	112dB(A) @ 1m	Tone 2	Tone 5
Tone 42	Motor Siren - slow rise to 800 Hz	114dB(A) @ 1m	Tone 2	Tone 5
Tone 43	1200 Hz Continuous	113dB(A) @ 1m	Tone 2	Tone 5
Tone 44	Motor Siren - slow rise to 2400 Hz	118dB(A) @ 1m	Tone 2	Tone 5
Tone 45	1KHz 1s on, 1s off Intermittent - PFEER Gen. Alarm	112dB(A) @ 1m	Tone 38	Tone 34

Country specific or custom tone configurations and alarm frequencies are available upon request.