

# SPECTRA B300STS

Synchronised Xenon Strobe Flashing Beacon

5J (Ws) @1.0 Hz

IP Rating: IP65

Temp : -25°C to +50°C

Unit weight: 325g DC : 300g AC

CE

Dimensions : Ø100 x 150mm

1.5mm<sup>2</sup> terminals

Cable entry: 1 x 5-7mm push through

grommet

1 x M20 cable entry (IP65)

Order code Voltage

B300STS012B/x 12V AC/DC 600mA

B300STS024B/x 24V AC/DC 300mA

B300STS048B/x 48V AC/DC 250mA

B300STS115B/x 115V AC 70mA

B300STS230B/x 230V AC 35mA

X = Lens colour

R = Red

B = Blue

G = Green

A = Amber

C = Clear

Y = Yellow

Mountings

B300RAB001 Right angle bracket

B300TMA001 Tube mounting assembly

Tel : +44 (0)20 8743 8880 Fax : +44(0)20 8740 4200

email : sales@e2s.com web : www.e2s.com



 **ATTENTION:** Installation must be carried out by an electrician in compliance with the latest codes and regulations.

 **ATTENTION:** Disconnect from power source before installation or service to prevent electric shock.

 **ATTENTION:** On strobe beacons allow a minimum of 2 minutes for hazardous high voltage to discharge from unit.

 **ATTENTION:** Lens on unit will be hot allow to cool prior to removal.



# A SPECIIRA B300STS

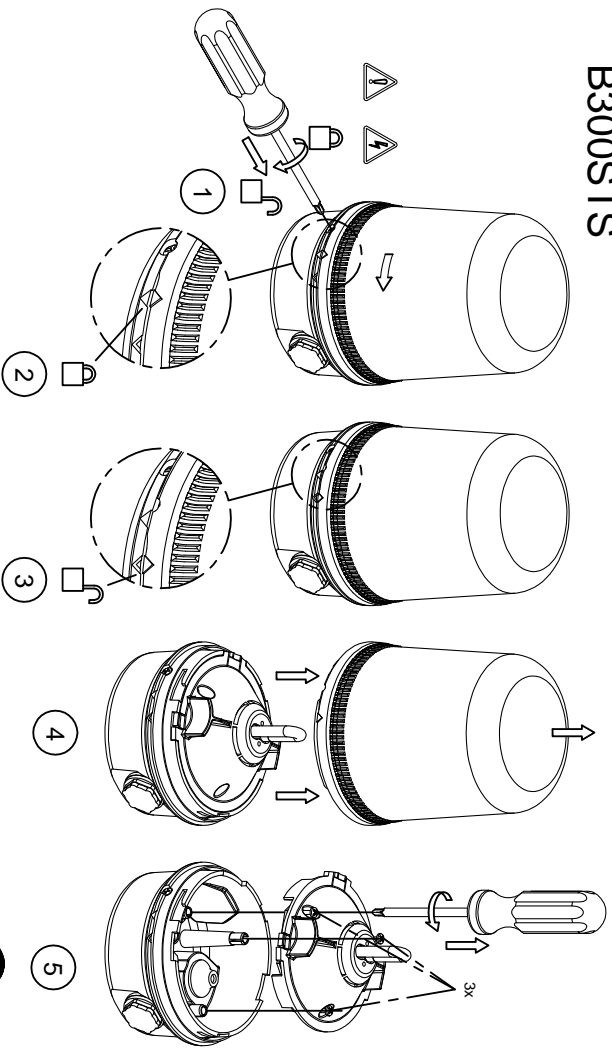

**B**

MOUNTING OPTIONS	
a	STANDARD BASE
b	POLE MOUNT
c	90° BRACKET

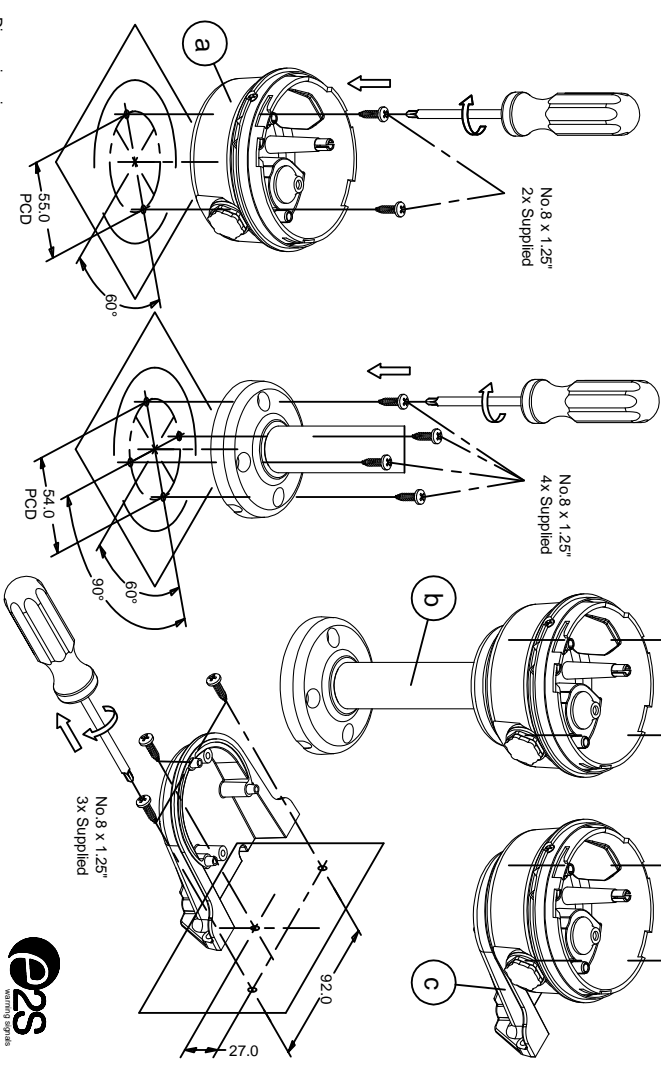

Tel : +44 (0)20 8743 8880 Fax : +44 (0)20 8740 4200  
 mail : sales@e2s.com web : www.e2s.com



Dimensions in mm



**C**

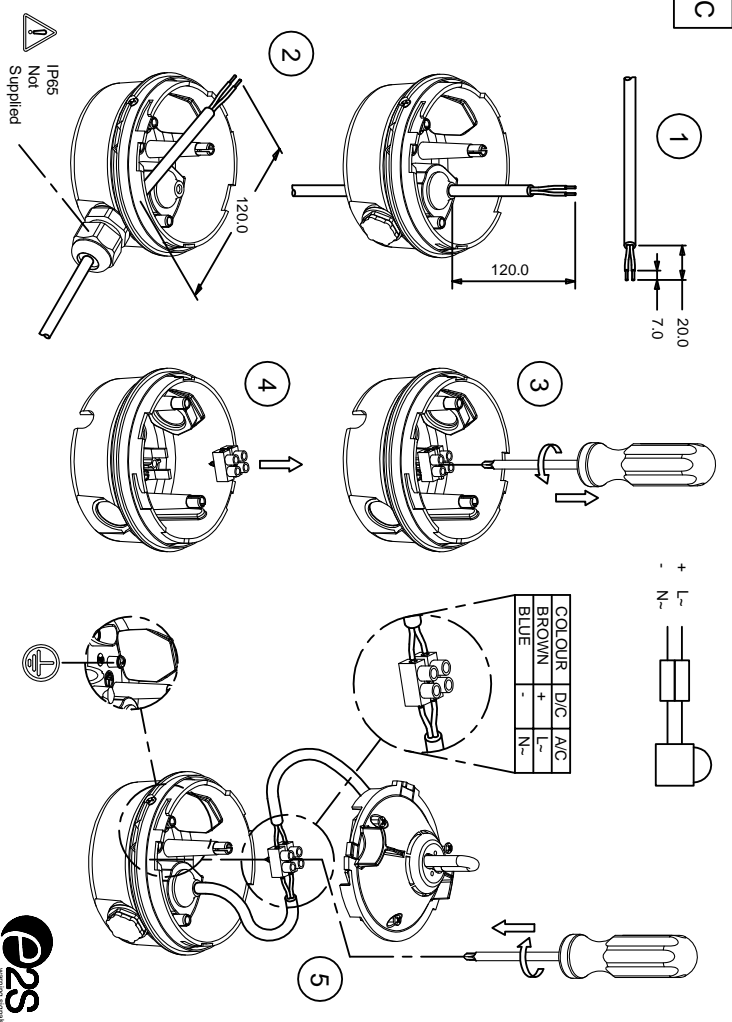

**D**

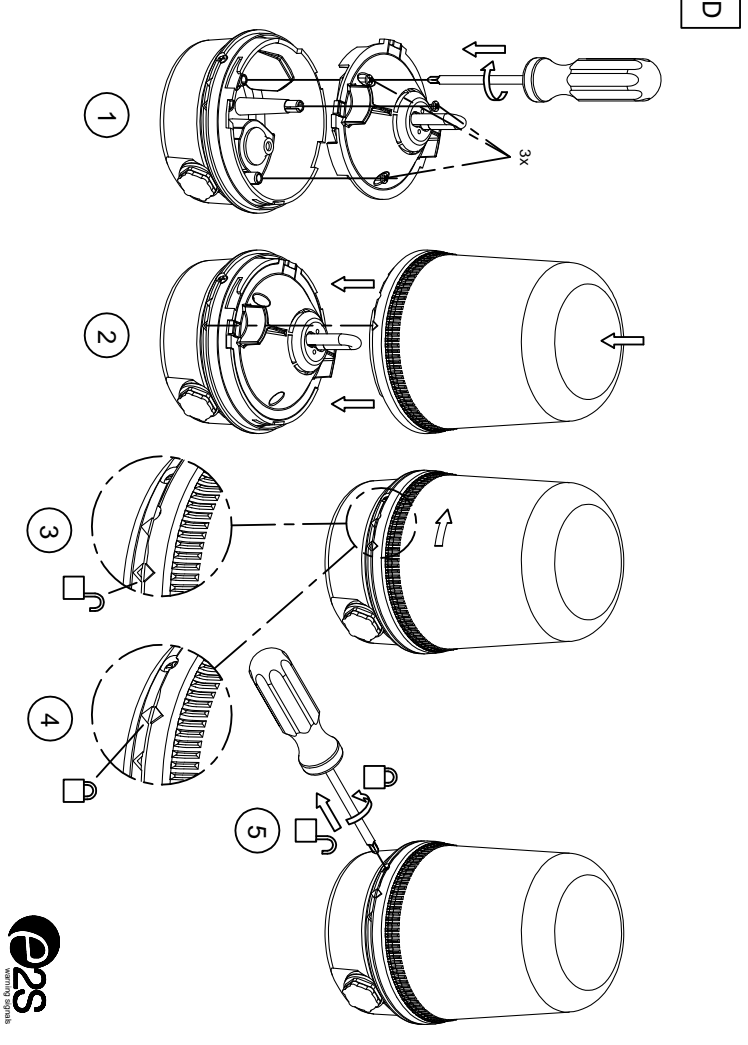

D11200-1011S-SHTZ-LS5UE-B